

EN

ORIGINAL INSTRUCTIONS
DEHUMIDIFIER



Table of contents

Notes regarding the instructions 2

Safety 2

Information about the device 4

Transport and storage 5

Assembly and installation 6

Operation 9

Available accessories 10

Errors and faults 10

Maintenance 11

Technical annex 15

Disposal 19

Declaration of conformity 19

Notes regarding the instructions

Symbols



Warning of electrical voltage

This symbol indicates dangers to the life and health of persons due to electrical voltage.



Warning

This signal word indicates a hazard with an average risk level which, if not avoided, can result in serious injury or death.



Caution

This signal word indicates a hazard with a low risk level which, if not avoided, can result in minor or moderate injury.

Note

This signal word indicates important information (e.g. material damage), but does not indicate hazards.



Info

Information marked with this symbol helps you to carry out your tasks quickly and safely.



Follow the manual

Information marked with this symbol indicates that the instructions must be observed.

You can download the current version of the instructions and the EU declaration of conformity via the following link:

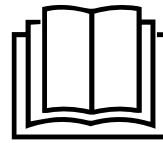

TTK 200



<https://hub.trotec.com/?id=42905>

Safety

Read this manual carefully before starting or using the device. Always store the manual in the immediate vicinity of the device or its site of use!



Warning

Read all safety warnings and all instructions.

Failure to follow the warnings and instructions may result in electric shock, fire and / or serious injury.

Save all warnings and instructions for future reference.

This appliance can be used by children aged from 8 years and above and persons with reduced physical, sensory or mental capabilities or lack of experience and knowledge if they have been given supervision or instruction concerning use of the appliance in a safe way and understand the hazards involved.

Children shall not play with the appliance. Cleaning and user maintenance shall not be made by children without supervision.

- Do not use the device in potentially explosive rooms.
- Do not use the device in aggressive atmosphere.
- Set the device up in an upright and stable position.
- Let the device dry out after a wet clean. Do not operate it when wet.
- Do not use the device with wet or damp hands.
- Do not expose the device to directly squirting water.
- Never insert any objects or limbs into the device.
- Do not cover or transport the device during operation.
- Do not sit on the device.
- This appliance is not a toy! Keep away from children and animals. Do not leave the device unattended during operation.
- Check accessories and connection parts for possible damage prior to every use of the device. Do not use any defective devices or device parts.

- Ensure that all electric cables outside of the device are protected from damage (e.g. caused by animals). Never use the device if electric cables or the power connection are damaged!
- The electrical connection must correspond to the specifications in chapter Technical data.
- Insert the mains plug into a properly secured mains socket.
- Observe the device's power input, cable length and intended use when selecting extensions to the power cable. Completely unroll extension cables. Avoid electrical overload.
- Before carrying out maintenance, care or repair work on the device, remove the mains plug from the mains socket. Hold onto the mains plug while doing so.
- Switch the device off and disconnect the power cable from the mains socket when the device is not in use.
- Do not under any circumstances use the device if you detect damages on the mains plug or power cable. If the supply cord is damaged, it must be replaced by the manufacturer, its service agent or similarly qualified persons in order to avoid a hazard. Defective power cables pose a serious health risk!
- When positioning the device, observe the minimum distances from walls and other objects as well as the storage and operating conditions specified in the Technical data chapter.
- Make sure that the air inlet and outlet are not obstructed.
- Make sure that the suction side is kept free of dirt and loose objects.
- Do not remove any safety signs, stickers or labels from the device. Keep all safety signs, stickers and labels in legible condition.
- Only transport the device in an upright position with an emptied condensation tank or drain hose.
- Discharge the collected condensate before transport and storage. Do not drink it. Health hazard!

Intended use

Only use the device as mobile construction dryer for drying and dehumidifying room air (e.g. after water damages from burst pipes or flooding) whilst adhering to the technical data. The construction dryer can be used at low temperatures of about 0 °C.

Intended use comprises:

- drying and dehumidifying:
 - production plants, underground rooms
 - store rooms, archives, laboratories
 - rooms and areas after water damages from burst pipes or flooding
- maintaining the dryness of:
 - instruments, devices, files
 - electric control devices, boiler plants, turbines and pipe systems in power plants
 - moisture-sensitive loads etc.

Improper use

- Do not place the device on wet or flooded ground.
- Do not place any objects, e.g. clothing, on the device.
- Do not use the device outdoors.
- Any unauthorised modifications, alterations or structural changes to the device are forbidden.
- Any operation other than as described in this manual is prohibited. Non-observance renders all claims for liability and guarantee null and void.

Personnel qualifications

People who use this device must:

- be aware of the dangers that occur when working with electric devices in damp areas.
- have read and understood the instructions, especially the Safety chapter.

Maintenance tasks which require the housing to be opened must only be carried out by specialist companies for cooling and air-conditioning or by Trotec.

Residual risks



Warning of electrical voltage

Work on the electrical components must only be carried out by an authorised specialist company!



Warning of electrical voltage

Before any work on the device, remove the mains plug from the mains socket!
Hold onto the mains plug while pulling the power cable out of the mains socket.



Warning

Dangers can occur at the device when it is used by untrained people in an unprofessional or improper way! Observe the personnel qualifications!



Warning

The device is not a toy and does not belong in the hands of children.



Warning

Risk of suffocation!
Do not leave the packaging lying around. Children may use it as a dangerous toy.

Note

Do not operate the device without an inserted air filter!
Without the air filter, the inside of the device will be heavily contaminated. This could reduce the performance and result in damage to the device.

Behaviour in the event of an emergency

1. Switch off the device.
2. In an emergency, disconnect the device from the mains feed-in: Hold onto the mains plug while pulling the power cable out of the mains socket.
3. Do not reconnect a defective device to the mains.

Information about the device

Description of the device

The device uses the principle of condensation to automatically dehumidify rooms.

The fan sucks damp room air through the air inlet, the air filter, the evaporator and to the condenser located behind it. The air is cooled at the cold evaporator until it is below the dew point. Water vapour contained in the room air precipitates on the evaporator fins as condensation or rime. The dehumidified, cooled air is slightly warmed at the condenser and blown out again. The drier air thus conditioned mixes with the air in the room. The humidity in the room where the device is positioned is reduced as air constantly circulates through the device.

Depending on the air temperature and the relative humidity, the condensed water either drops continuously or only during the defrost phase through the integrated drain nozzle into the condensation tank below. It is fitted with a float to measure the filling level.

Optionally, the condensed water can also be discharged by means of a hose attached to the condensation connection or using a retrofitted condensate pump (see chapter Installing the condensate pump).

For easy operation and transport, the device is fitted with an on / off switch, an operating hours counter, a transport handle and wheels. Two feet with rubber buffers prevent the device from rolling away.

The device can reduce the relative humidity of a room to approx. 35 %.

Because of the heat radiation generated during operation, the room temperature may rise slightly.

Device depiction

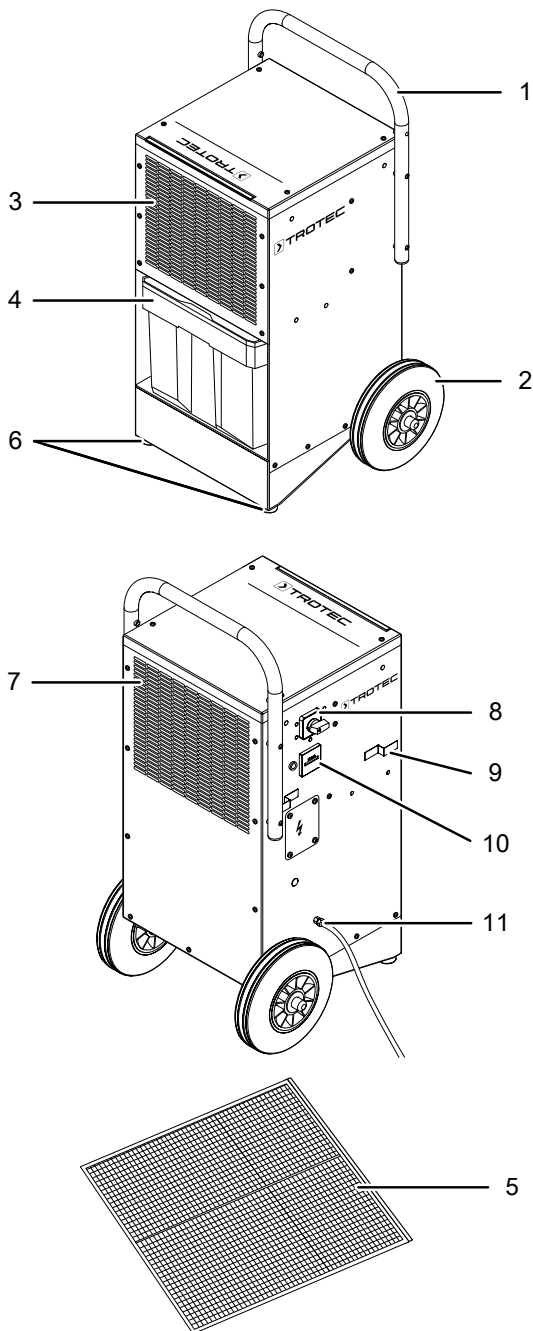

No.	Designation
1	Transport handle
2	Wheels
3	Air inlet with air filter
4	Condensation tank
5	Air filter
6	Feet with rubber buffers
7	Air outlet
8	On/off switch
9	Power cable holder
10	Operating hours counter optionally: dual counter for operating and kilowatt hours
11	Power cable

Transport and storage

Note

If you store or transport the device improperly, the device may be damaged.
Note the information regarding transport and storage of the device.

Transport

To make the device easier to transport, it is fitted with a transport handle and two wheels.

Before transporting the device, observe the following:

- Switch off the device.
- Hold onto the mains plug while pulling the power cable out of the mains socket.
- Do not use the power cable to drag the device.
- Drain the remaining condensate from the device and the condensation drain hose (see chapter Maintenance).
- Do not incline the device by more than 45°, for otherwise the device could be damaged.
- Only wheel the device on a level and smooth surface.

After transporting the device, observe the following:

- Set up the device in an upright position after transport.
- After having transported the device in horizontal position, leave the device to rest for 12 to 24 hours, so the refrigerant can accumulate within the compressor. Wait 12 to 24 hours before switching the device back on! Acting contrary might lead to compressor damage and a malfunctioning device. Any warranty claims will be voided in this case.

Storage

Before storing the device, proceed as follows:

- Drain the remaining condensate from the device and the condensation drain hose (see chapter Maintenance).
- Hold onto the mains plug while pulling the power cable out of the mains socket.
- Drain any possibly remaining condensate.

When the device is not being used, observe the following storage conditions:

- dry and protected from frost and heat
- in an upright position where it is protected from dust and direct sunlight
- with a cover to protect it from invasive dust, if necessary
- Place no further devices or objects on top of the device to prevent it from being damaged.

Assembly and installation

Scope of delivery

- 1 x Device
- 1 x Air filter
- 1 x Manual

Unpacking the device

1. Open the cardboard box and take the device out.
2. Completely remove the packaging.
3. Fully unwind the power cable. Make sure that the power cable is not damaged and that you do not damage it during unwinding.

Start-up

When positioning the device, observe the minimum distance from walls or other objects as described in the Technical data chapter.

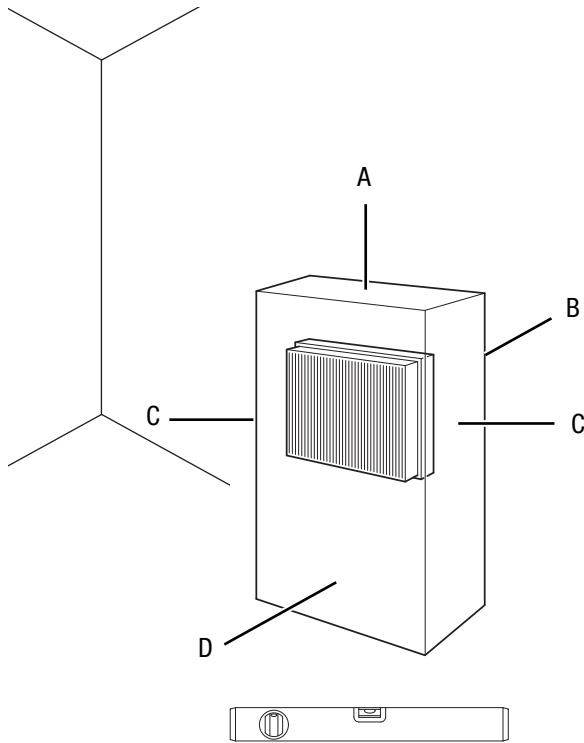

- Before restarting the device, check the condition of the power cable. If there are doubts as to the sound condition, contact the customer service.
- Set the device up in an upright and stable position.
- Do not create tripping hazards when laying the power cable or other electric cables, especially when positioning the device in the middle of the room. Use cable bridges.
- Make sure that extension cables are completely unrolled.
- When positioning the device, keep a sufficient distance to heat sources.

- Make sure that no curtains or other objects interfere with the air flow.
- When positioning the device, particularly in wet areas, secure it locally with an RCD (residual current device) which complies with the respective regulations.

Relocating the transport handle

Depending on your requirements, the transport handle can be installed horizontally or vertically. The transport handle can be assembled in two horizontal positions (upper or lower). To adjust the position of the transport handle, carry out the following steps on both sides of the device:

Transport handle in the upper position

1. Loosen and remove the screws marked at positions (15), (16) and (18).

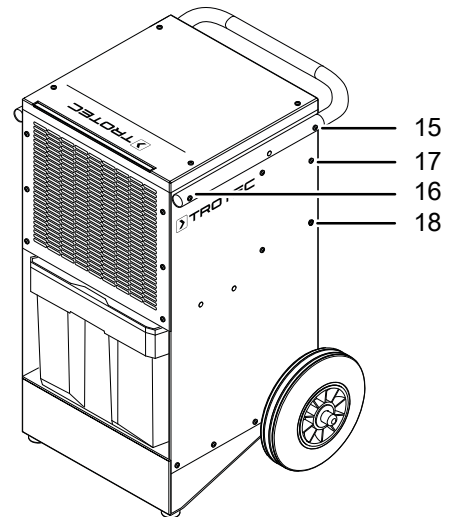

2. Turn the handle by 90° and attach it to the device in the desired position.
3. Insert the screws from positions (15) and (16) into the openings of position (15) and (18) and tighten them.

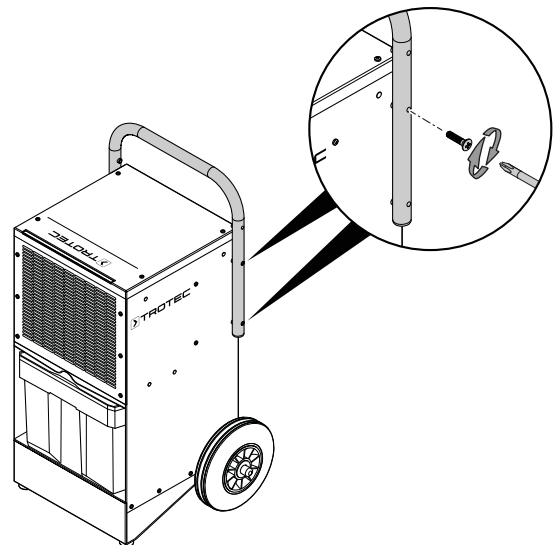

4. Insert the screw from position (18) into the opening of position (16) and tighten it.

Transport handle in the lower position

1. Loosen and remove the screws marked at positions (15), (16) and (17).

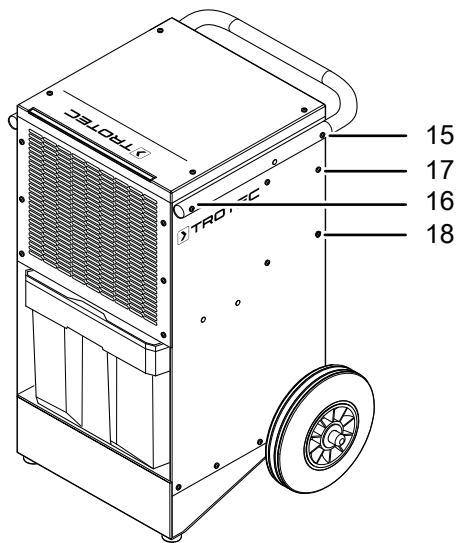

2. Turn the handle by 90° and attach it to the device in the desired position.
3. Insert the screws from positions (15) and (16) into the openings of position (15) and (17) and tighten them.

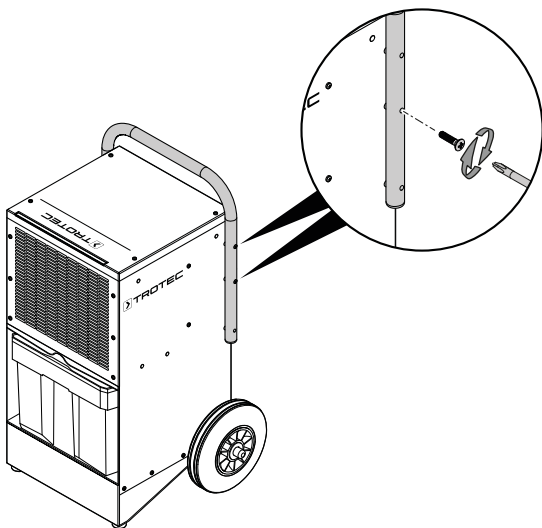

4. Insert the screw from position (17) into the opening of position (16) and tighten it.

Inserting the air filter

Note

Do not operate the device without an inserted air filter! Without the air filter, the inside of the device will be heavily contaminated. This could reduce the performance and result in damage to the device.

- Make sure that the air filter is installed before switching the device on.

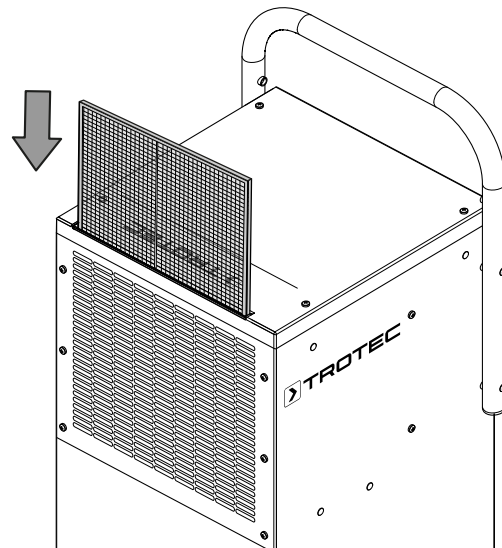

Positioning the condensation drain hose

For continuous operation or unattended dehumidification, please connect the supplied condensation drain hose to the device.

- ✓ A suitable hose (diameter: 16 mm) is ready for use.
- ✓ The device is switched off.

1. Remove the condensation tank.

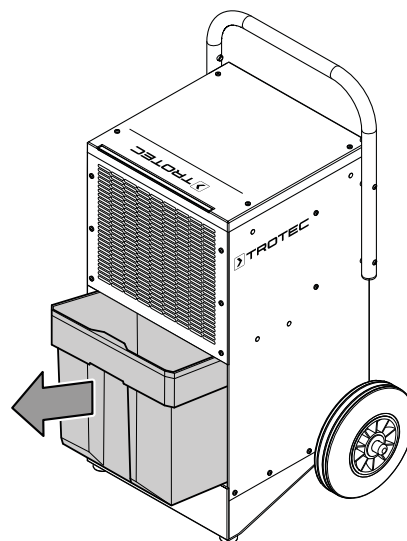

2. Connect the condensation drain hose to the condensation hose connection at the device.

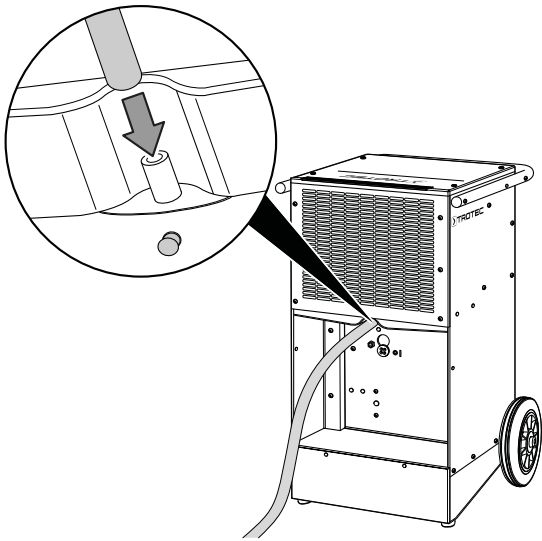

- ⇒ Position the end of the condensation drain hose above a water drain. For larger distances, a longer hose of the same type can also be used.

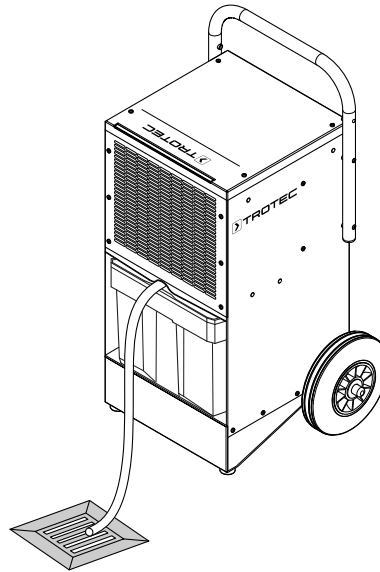

3. Make sure that the condensation drain hose is properly connected to the device and free of damage.
 4. Depending on the application, position the other end of the condensation drain hose as follows:
 ⇒ Place a sufficiently dimensioned container (at least 90 litres) beside the device and insert the hose end. Check the filling level of the container regularly.

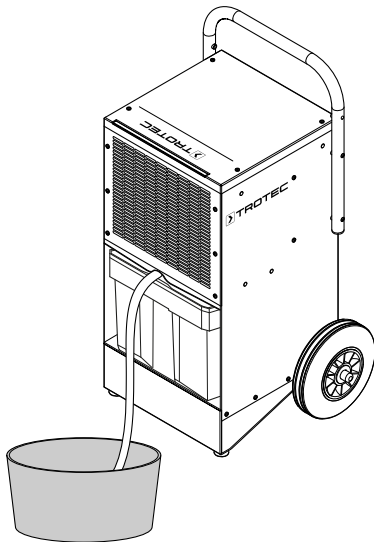

5. Make sure that the condensation drain hose is installed with a continuous decline.

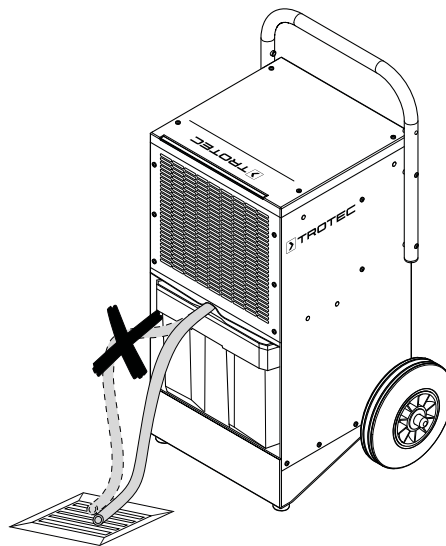

Condensate pump (optional)

For continuous operation or unattended dehumidification the condensed water can optionally also be discharged from the device by means of a retrofitted condensate pump (see chapter Available accessories).

Operation

- Avoid open doors and windows.
- After being switched on, the device operates fully automatically.
- During operation with an external hygrostat (optional) the fan continues to run in dehumidification mode until the device is switched off even after having reached the set target value.

Operating elements

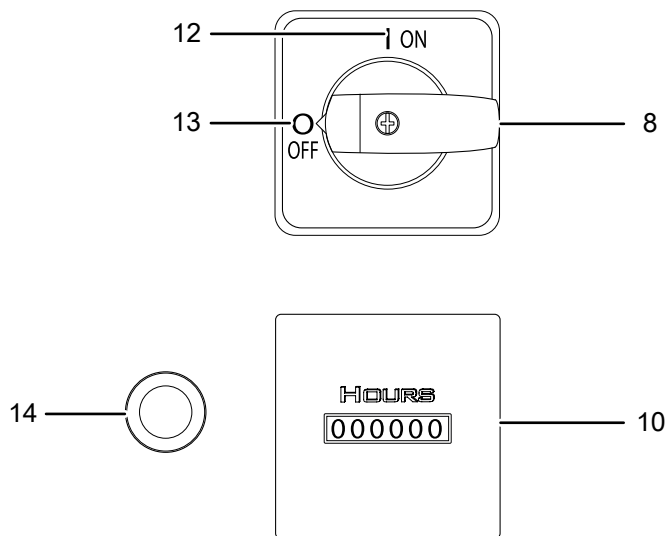

No.	Designation	Meaning
8	On/off switch	For switching the device on or off
10	Operating hours counter Optionally: dual counter for operating and kilowatt hours	Indication of operating hours Indication of operating hours and power consumption
12	ON position	Device switched on
13	OFF position	Device switched off
14	Indicator light	Illuminated during operation

Switching the device on

Once you have completely installed the device as described in the Start-up chapter, you can switch it on.

1. Turn the on / off switch (8) to the *ON* position (12).
 - ⇒ The device is switched on.
 - ⇒ The compressor always starts with a delay of approx. 7 s.
 - ⇒ The fan starts approx. 10 s after that.

Continuous operation mode

In continuous operation mode, the device dehumidifies the air constantly, regardless of the humidity.

Hygrostat operation mode (optional)

The device can also be operated with a hygrostat. The hygrostat switches the device on or off depending on the relative humidity.

If you choose to operate the device with an optional hygrostat, set the desired relative humidity at the hygrostat (see instructions of the optional hygrostat).

In doing so, observe the switching point. Provided the external hygrostat activates the compressor via the set humidity value, then hygrostat and drying unit operate correctly. You can tell the incorrect operation of the external hygrostat if the compressor of the device operates below the set value and switches off above it. In this case you need to open the hygrostat and reconnect the connections.

Automatic defrost

At low ambient temperatures, ice may form at the evaporator during dehumidification. The device will then carry out an automatic defrost. Dehumidification is briefly interrupted during defrosting. The fan keeps running.

The duration of the defrost process can vary. Do not switch off the device during automatic defrost. Do not remove the mains plug from the mains socket.

Shutdown



Warning of electrical voltage

Do not touch the mains plug with wet or damp hands.

- Switch off the device.
- Hold onto the mains plug while pulling the power cable out of the mains socket.
- If necessary, remove the condensation drain hose and any residual fluid from it.
- Clean the device according to the Maintenance chapter.
- Store the device according to the Storage chapter.

Available accessories



Warning

Only use accessories and additional equipment specified in the instructions. Using insertion tools or accessories other than those specified in the instructions may cause a risk of injury.

Designation	Article number
Optional hygrostat for TTK 200	7.430.000.934
External hygrostat HG 130	6.100.002.045
Condensate pump TTK 200 incl. installation kit	6.100.003.005
Dew point control HG 140	6.100.002.050
Starting current limiter ASB 3500	6.100.002.030
Air filter for TTK 200	7.160.000.011

Errors and faults

The device has been checked for proper functioning several times during production. If malfunctions occur nonetheless, check the device according to the following list.

The device does not start:

- Check the power connection.
- Check the power cable and mains plug for damages.
- Check the on-site fusing.
- If you operate the device with a hygrostat (optional), check the set value. In order for the construction dryer to operate, the humidity level at the installation site needs to be higher than the set value. Set the hygrostat to a lower value.

The device is running, but there is no formation of condensate:

- Check whether the condensation drain hose is positioned correctly.
- When using the condensate pump: Check the condensation tank and hoses for dirt.
- Ensure that the relative room humidity complies with the technical data.
- If you operate the device with a hygrostat (optional), check the set value. In order for the construction dryer to operate, the humidity level at the installation site needs to be higher than the set value. Set the hygrostat to a lower value.
- Check the air filter for dirt. If necessary, clean or replace the air filter.

- From the outside, check the condenser for dirt (see chapter Maintenance). If the condenser is dirty, have it cleaned by a specialist company or by Trotec.
- The device might carry out an automatic defrost. During automatic defrost, the device does not dehumidify.

The device is loud or vibrates:

- Check whether the device is set up in a stable and upright position.

Condensate is leaking:

- Check the device for leaks.

The compressor does not start:

- Check the room temperature. Observe the device's permissible operating range according to the technical data.
- Check whether the overheating protection of the compressor has tripped. Disconnect the device from the mains and let it cool down for approx. 10 minutes before reconnecting it.
- The device might carry out an automatic defrost. During automatic defrost, the device does not dehumidify.

The device gets very warm, is loud or loses power:

- Check the air inlets and air filters for dirt. Remove external dirt.
- From the outside, check the device for dirt (see chapter Maintenance). If the inside of the device is dirty, have it cleaned by a specialist company for cooling and air-conditioning or by Trotec.

Note

Wait for at least 3 minutes after maintenance and repair work. Only then switch the device back on.

Your device still does not operate correctly after these checks?

Please contact the customer service. If necessary, bring the device to a specialist company for cooling and air-conditioning or to Trotec for repair.

Maintenance

Maintenance intervals

Maintenance and care interval	before every start-up	as needed	at least every 2 weeks	at least every 4 weeks	at least every 6 months	at least annually
Empty the condensate pump, condensation tank and construction dryer and clean if necessary		X				
Check air inlets and outlets for dirt and foreign objects and clean if necessary	X			X		
Clean the exterior		X				X
Visually check the inside of the device for dirt		X		X		
Clean the inside with compressed air		X				X
Check the air inlet grid and air filter for dirt and foreign objects and clean or replace if necessary	X		X			
Replace the air filter					X	
Check for damage	X					
Check the attachment screws		X				X
Test run						X

Maintenance and care log

Device type:

Device number:

Maintenance and care interval	1	2	3	4	5	6	7	8	9	10	11	12	13	14	15	16
Empty the condensate pump, condensation tank and construction dryer and clean if necessary																
Check air inlets and outlets for dirt and foreign objects and clean if necessary																
Clean the exterior																
Visually check the inside of the device for dirt																
Clean the inside with compressed air																
Check the air inlet grid and air filter for dirt and foreign objects and clean or replace if necessary																
Replace the air filter																
Check for damage																
Check the attachment screws																
Test run																
Remarks:																

1. Date: Signature:	2. Date: Signature:	3. Date: Signature:	4. Date: Signature:
5. Date: Signature:	6. Date: Signature:	7. Date: Signature:	8. Date: Signature:
9. Date: Signature:	10. Date: Signature:	11. Date: Signature:	12. Date: Signature:
13. Date: Signature:	14. Date: Signature:	15. Date: Signature:	16. Date: Signature:

Activities required before starting maintenance



Warning of electrical voltage

Do not touch the mains plug with wet or damp hands.

- Switch the device off.
- Hold onto the mains plug while pulling the power cable out of the mains socket.



Warning of electrical voltage

Tasks which require the housing to be opened must only be carried out by authorised specialist companies or by Trotec.

Cleaning the housing

Clean the housing with a soft, damp and lint-free cloth. Ensure that no moisture enters the housing. Protect electrical components from moisture. Do not use any aggressive cleaning agents such as cleaning sprays, solvents, alcohol-based or abrasive cleaners to dampen the cloth.

Visual inspection of the inside of the device for dirt

1. Remove the air filter.
2. Use a torch to illuminate the openings of the device.
3. Check the inside of the device for dirt.
4. If you see a thick layer of dust, have the inside of the device cleaned by a specialist company for cooling and air-conditioning or by Trotec.
5. Put the air filter back in.

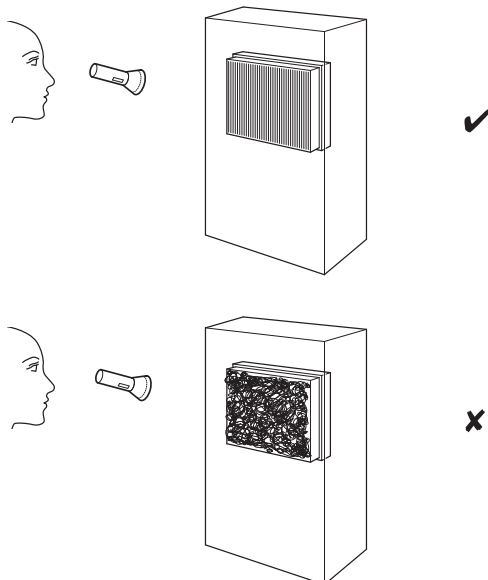

Cleaning the air filter

Note

Ensure that the air filter is not worn or damaged. The corners and edges of the air filter must not be deformed or rounded. Before reinserting the air filter, make sure that it is undamaged and dry!

The air filter has to be cleaned as soon as it is dirty. This is brought to light e.g. by a reduced capacity (see chapter Errors and faults).

1. Remove the air filter from the device.

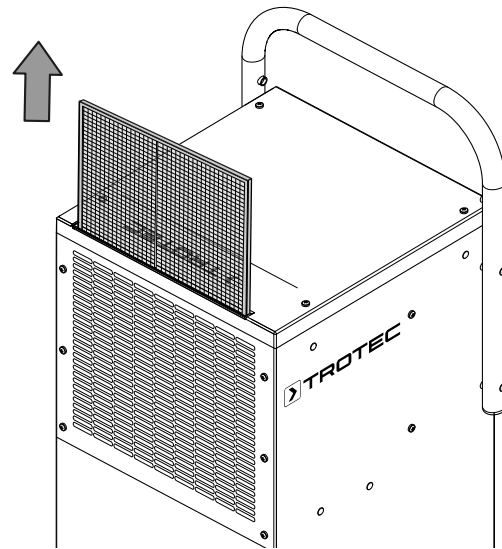

2. Clean the filter using a slightly damp, soft, lint-free cloth. If the filter is heavily contaminated, clean it with warm water mixed with a neutral cleaning agent.

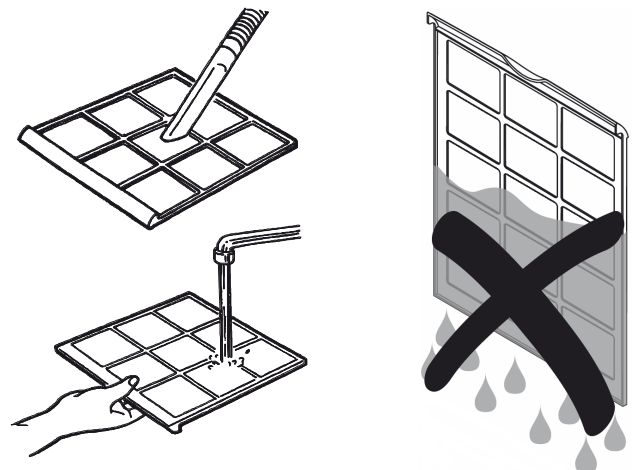

Refrigerant circuit

- The entire refrigerant circuit is a maintenance-free, hermetically sealed system and may only be maintained or repaired by specialist companies for cooling and air-conditioning or by Trotec.

3. Allow the filter to dry completely. Do not insert a wet filter into the device!
4. Reinsert the air filter into the device.

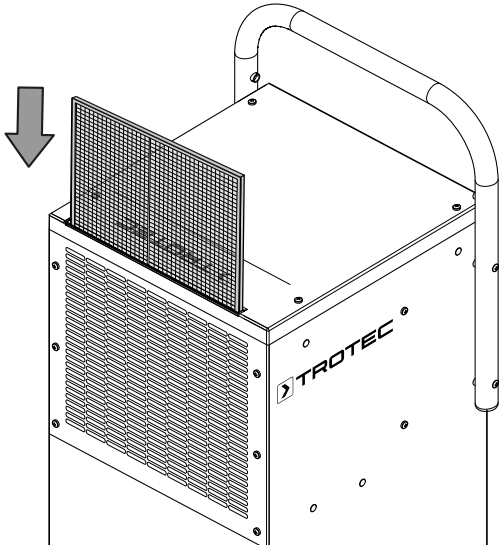

Cleaning the inside with compressed air



Warning

Risk of injury caused by ejected compressed air upon activation of the compressed air supply. Hold the compressed-air hose away from your body. Pointing the compressed-air hose at another person is prohibited.

The housing cover has to be removed in order to perform cleaning and maintenance tasks inside the device.

1. Loosen and remove the four screws at the top of the device.

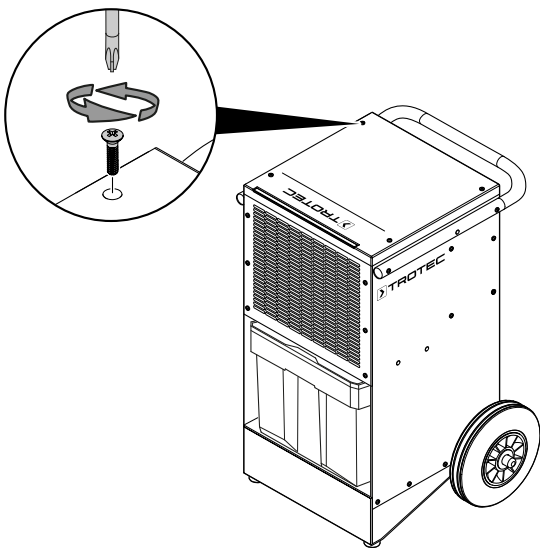

2. Keep the four screws safe for later use.

3. Lift the housing cover off the device.

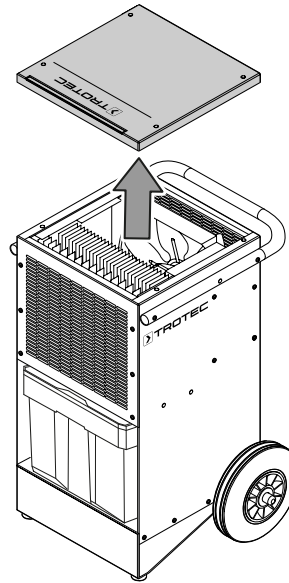

4. Carefully set the housing cover aside.
5. Clean the interior of the device by means of compressed air.

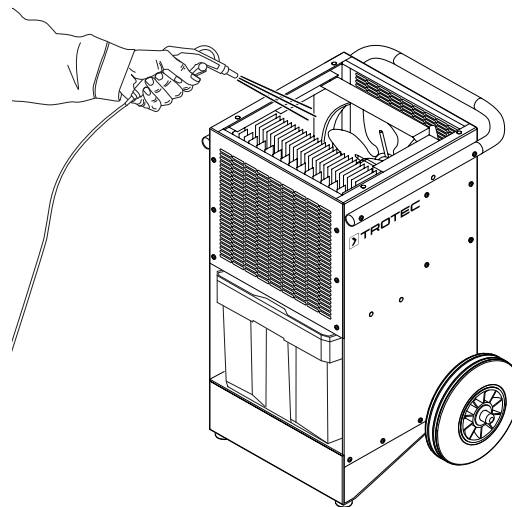

6. Reassemble the housing cover on the device.

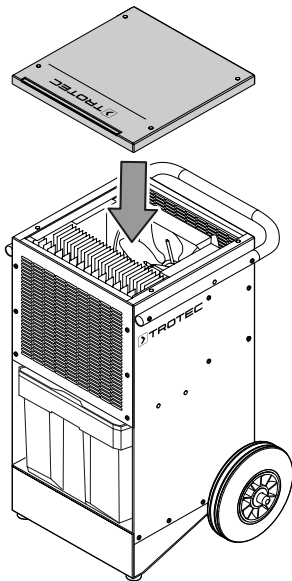

7. Finally retighten all screws.

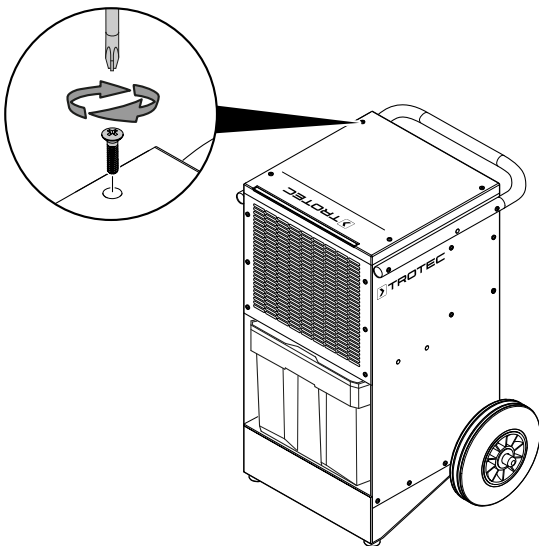

Activities required after maintenance

If you want to continue using the device:

- Reconnect the device to the mains.

If you do not intend to use the device for a considerable time:

- Store the device according to the Storage chapter.

Technical annex

Technical data

Parameter	Value
Model	TTK 200
Max. dehumidification performance	35 l / 24 h
Dehumidification performance at 30 °C and 80 % RH	25 l / 24 h
Air flow rate	230 m ³ /h
Operating range (temperature)	0 °C to 40 °C
Operating range (relative humidity)	35 % to 100 % RH
Pressure suction side	0.7 MPa
Pressure outlet side	2.7 MPa
Mains voltage	1/N/PE ~ 230 V / 50 Hz
Max. power input	0.8 kW
Nominal current	2.8 A
Refrigerant	R-407C
Amount of refrigerant	370 g
GWP factor	1,774
CO ₂ equivalent	0.66 t
Water tank	11 l
Sound pressure level (at a distance of 3 m)	52 dB(A)
Dimensions (length x width x height)	480 x 510 x 720 mm
Minimum distance to walls and other objects	A: top 50 cm B: rear 50 cm C: side 50 cm D: front 50 cm
Weight	34 kg

Circuit diagram

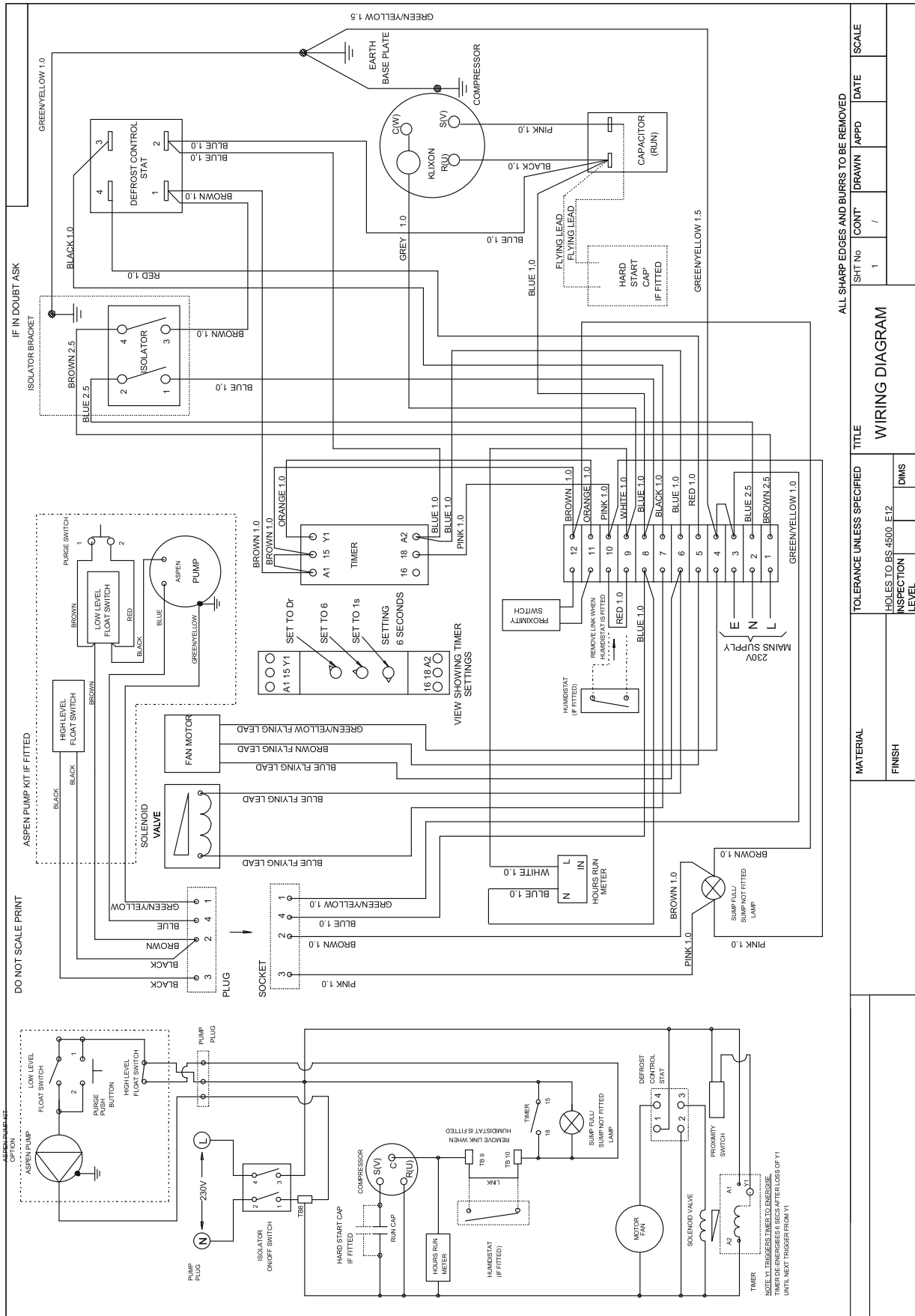

TOLERANCE UNLESS SPECIFIED		TITLE		SCALE	
Holes to BS 4500 E12		WIRING DIAGRAM		DATE	
INSPECTION LEVEL		SHT No		DRAWN APPD	
FINISH		1 /		CONT	
MATERIAL		ALL SHARP EDGES AND BURRS TO BE REMOVED		DATE	

Overview and list of spare parts

Note: The position numbers of the spare parts differ from those describing the positions of the components mentioned in these instructions.

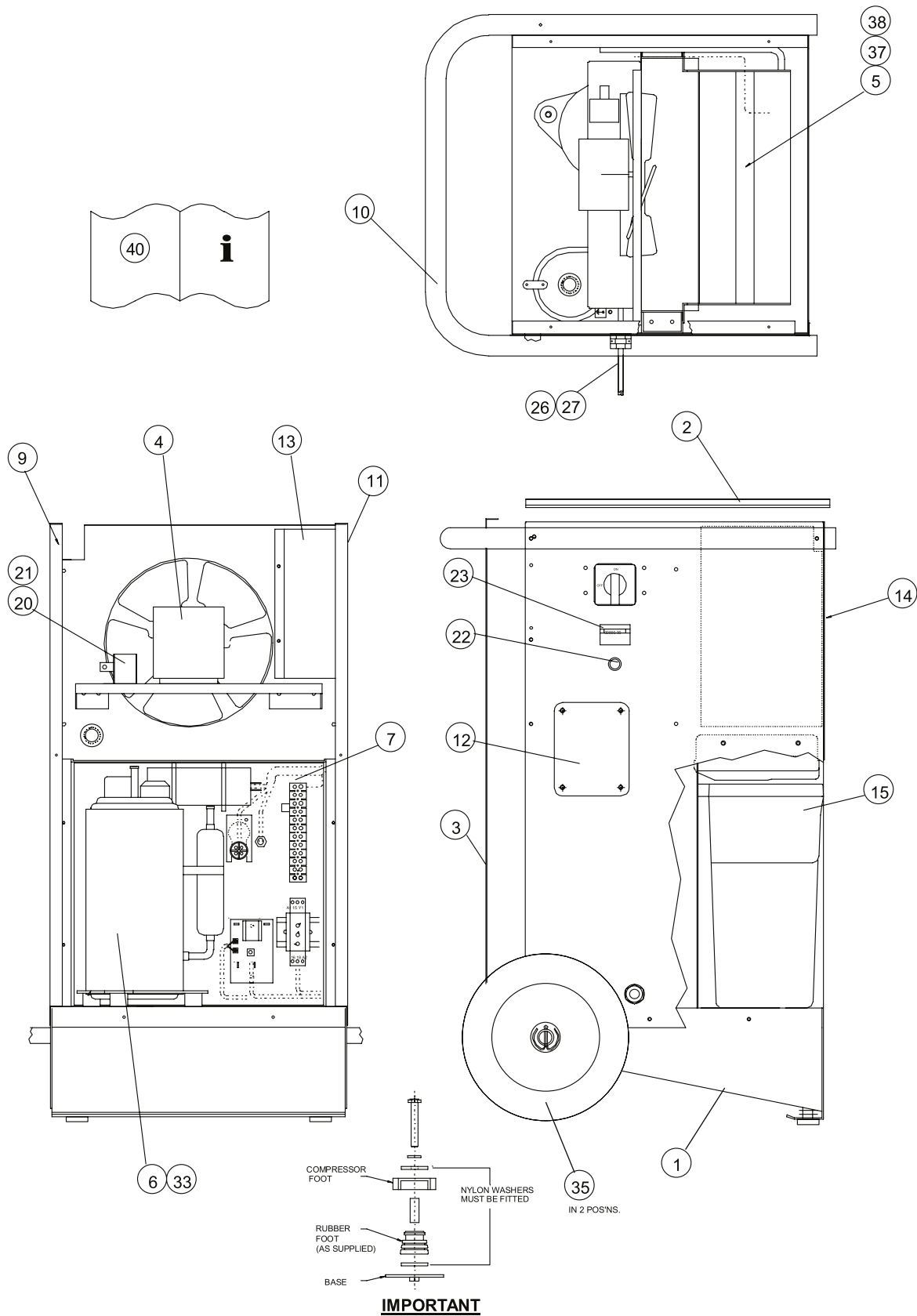

ITEM NO.	DESCRIPTION	QTY.	ITEM NO.	PART NUMBER	QTY.
1	BASE PLATE	1	15	WATER CONTAINER ASSY	1
2	TOP COVER	1	20	SOLENOID COIL 1/4	1
3	COVER PANEL	1	21	DEFROST VALVE	1
4	MOTOR AND BLADE	1	22	PILOT LIGHT AMBER 240V	1
5	EVAP/COND ASSY	1	23	HOURS RUN METER (PANEL MOUNT)	1
6	ROTARY COMPRESSOR QXC-10K 1FN1	1	26	M20 PLASTIC GLAND BACK NUT	1
7	ELECTRIC PANEL ASSY	1	27	PLUG/LEAD ASSEMBLY	1
9	SIDE PANEL	1	33	REFRIGERANT R407C	0.37
10	HANDLE	1	35	WHEEL 200mm DIA	2
11	SIDE PANEL CONTROLS	1	37	DRIER, LITTLE GIANT 90mm	1
12	BLANKING PLATE	1	38	CAPILLARY 0.052" BORE	1016
13	SHIELD PLATE	1	40	OWNER MANUAL	1
14	INLET GRILLE	1			

Disposal



The icon with the crossed-out waste bin on waste electrical or electronic equipment stipulates that this equipment must not be disposed of with the household waste at the end of its life. You will find collection points for free return of waste electrical and electronic equipment in your vicinity. The addresses can be obtained from your municipality or local administration. For further return options provided by us please refer to our website www.trotec24.com.

The separate collection of waste electrical and electronic equipment aims to enable the re-use, recycling and other forms of recovery of waste equipment as well as to prevent negative effects for the environment and human health caused by the disposal of hazardous substances potentially contained in the equipment.

The device is operated with fluorinated greenhouse gas which can be dangerous for the environment and contribute to global warming when emitted to the atmosphere.

Further information is provided on the nameplate.

Dispose of the refrigerant appropriately and according to the national regulations.

Declaration of conformity

The text below sets out the contents of the declaration of conformity. The signed declaration of conformity can be found at <https://hub.trotec.com/?id=42905>.

Declaration of conformity

In accordance with the EC Machinery Directive 2006/42/EC, Annex II, part 1, Section A

Herewith, we – Trotec GmbH & Co. KG – declare that the machinery designated below was developed, constructed and produced in compliance with the requirements of the EC Machinery Directive in the version 2006/42/EC.

Product model / Product: TTK 200

Product type: dehumidifier

Year of manufacture as of: 2018

Relevant EU directives:

- 2002/95/EC: 13.02.2003
- 2014/30/EU: 29 March 2014

Applied harmonised standards:

- EN ISO 12100:2010
- EN ISO 13850:2015
- EN ISO 13857:2008
- EN 60335-1:2012/A11:2014
- EN 60335-2-40:2003/A13:2012
- EN 61000-3-2:2000
- EN 61000-3-3:1995+A1:2001
- EN 61000-6-03:2001

Applied national standards and technical specifications:

- None

Manufacturer and name of the authorised representative of the technical documentation:

Trotec GmbH & Co. KG

Grebberer Straße 7, D-52525 Heinsberg

Phone: +49 2452 962-400

E-mail: info@trotec.de

Place and date of issue:

Heinsberg, 07.04.2009

Detlef von der Lieck, Managing Director

Trotec GmbH & Co. KG

Grebener Str. 7
D-52525 Heinsberg

☎ +49 2452 962-400

☎ +49 2452 962-200

info@trotec.com

www.trotec.com